	First Issued	07 August 1998
	Reviewed	28 June 2016
	Version	1.0
	Author	SFSE Seppelt (MFS) FSO Paton (CFS)
	Authorised by	ACFO Kilsby (MFS) CO Nettleton (CFS)

SOUTH AUSTRALIAN FIRE AUTHORITIES

BUILT ENVIRONMENT SECTION POLICY NO. 14

Above Ground Water Storage Tanks for Fire Fighting Purposes

BUILT ENVIRONMENT SECTION POLICY 14: ABOVE GROUND WATER STORAGE TANKS FOR FIRE FIGHTING PURPOSES

DOCUMENT CONTROLS

Revision History:

Version	Revision Description	Date
F	First issue	07 July 2008
1.0	General Departmental review	28 June 2016

List of Amendments:

Clause	Amendment
Document control/revision history	added
Table of contents	added
Glossary	added
Definitions	added
Referenced Standards	added
General	minor revisions and formatting

BUILT ENVIRONMENT SECTION POLICY 14: ABOVE GROUND WATER STORAGE TANKS FOR FIRE FIGHTING PURPOSES

CONTENTS

GLOSSARY	4
DEFINITIONS	5
REFERENCED STANDARDS	6
1 PURPOSE.....	7
2 SCOPE.....	7
3 GENERAL	7
4 FIRE APPLIANCE ACCESS.....	7
5 STORAGE TANK CONNECTIONS, VALVES AND ACCESSORIES.....	8
5.1 Connections.....	8
5.1.1 CFS Areas	8
5.1.2 MFS Areas.....	8
5.1.3 Dual Response (Mutual Aid) Areas	8
5.2 Suction Isolating Valve.....	8
5.3 General Pipe and Valve Requirements	9
5.4 MFS Net Positive Suction Head Requirements	9
5.5 Quick Fill Facilities	9
5.6 Vortex Inhibitor (Anti-Cavitation Plate)	10
5.7 Tank Contents Indicator.....	10
5.8 Signage	10
6 TANK CAPACITIES.....	11
7 OVERFLOWS & MICROBIOLOGICAL AIR BREAKS.....	11
8 MULTIPLE TANKS	12
9 EXAMPLES OF SYSTEM ARRANGEMENTS.....	12

BUILT ENVIRONMENT SECTION POLICY 14: ABOVE GROUND WATER STORAGE TANKS FOR FIRE FIGHTING PURPOSES

GLOSSARY

AS	Australian Standard
AS/NZS	Australian/New Zealand Standard
BCA	Building Code of Australia
CFS	South Australian Country Fire Service
MFS	South Australian Metropolitan Fire Service
NCC	National Construction Code

BUILT ENVIRONMENT SECTION POLICY 14: ABOVE GROUND WATER STORAGE TANKS FOR FIRE FIGHTING PURPOSES

DEFINITIONS

For the purpose of this document, the following definitions apply.

Dual Response Areas (also referred to as Mutual Aid Areas)

Any defined area adjacent to the SAMFS/CFS boundary that is mutually agreed and documented for Mutual Aid purposes and that may initiate a response from either fire service. (MFS SOP No. 7)

Hardstand

(As per AS 2419.1)

An identifiable and clearly marked trafficable all-weather, self-draining pavement providing access and capable of supporting a fire brigade pumping appliance during firefighting operations in the order of 21T GVM.

Note: Examples of pavements are bituminous concrete, compacted aggregate, concrete or similar surfaces.

BUILT ENVIRONMENT SECTION POLICY 14: ABOVE GROUND WATER STORAGE TANKS FOR FIRE FIGHTING PURPOSES

REFERENCED STANDARDS

The following Australian (and other) Standards are referred to in this Schedule:

AS 1851	Australian Standard 1851 – <i>Maintenance of fire protection systems and equipment</i>
AS 2118	Australian Standard 2118 - <i>Automatic fire sprinkler systems</i>
AS 2419	Australian Standard 2419 - <i>Fire hydrant installations</i>
AS 3500 (set)	Australian/New Zealand Standard 3500 Set – <i>Plumbing and drainage</i>
Minister's Specification SA H3.2	<i>Concessions and specific requirements for farm buildings</i>
SAMFS Equipment Specification 001	<i>Storz Couplings, Adaptors & Reducers</i>

BUILT ENVIRONMENT SECTION POLICY 14: ABOVE GROUND WATER STORAGE TANKS FOR FIRE FIGHTING PURPOSES

1 PURPOSE

To provide advice specifying the requirements of the South Australian fire authorities, being the South Australian Metropolitan Fire Service (MFS) and the South Australian Country Fire Service (CFS) as per the South Australian Development Act 1993, in regards to above ground water storage tanks for firefighting purposes.

2 SCOPE

This policy applies to above ground external water storage tanks used for firefighting purposes as typically found adjacent to commercial buildings. This policy specifies additional provisions to the requirements found in the relevant Australian Standards for water storage tanks for firefighting purposes.

Water for firefighting for residential premises in bushfire prone areas is subject to Minister's Specification SA 78.

3 GENERAL

Firefighting water storage tanks shall be of approved size, accessible by a fire appliance and incorporate valves and water connections as nominated in this document.

Two tanks must be provided where the floor area of the building or combined area of buildings served exceeds 2,000m². In all other cases a single tank may be provided.

See Section 5 for details on the required tank and fire service connections.

It is recommended that specific advice be obtained from the relevant fire authority before any fire tank system is constructed.

4 FIRE APPLIANCE ACCESS

Tanks shall be located such that appliance hardstand areas are located no closer than 10m to any building or fire source feature. The hardstand must be provided adjacent to the tanks so that a fire brigade pumping appliance can be positioned with its pump inlet connection not more than **4.5 metres** from the tank suction connection. Refer Figure 7 for typical hardstand arrangements.

Where two large bore connections are installed, the distance between the connections must be not less than **10 metres**.

The hard standing must be horizontal and 450 - 600mm below the centreline of the large bore suction connection.

Where a building is not sprinkler protected and tanks are located within 10m of the building, they shall be constructed of concrete or steel, or be provided with a 90/90/90 radiant heat barrier of an appropriate size between it and the building.

The use of in ground tanks requires special consideration by the relevant fire authority.

BUILT ENVIRONMENT SECTION POLICY 14: ABOVE GROUND WATER STORAGE TANKS FOR FIRE FIGHTING PURPOSES

5 STORAGE TANK CONNECTIONS, VALVES AND ACCESSORIES

5.1 Connections

All suction connections provided shall be Storz connections in accordance with MFS Equipment Specification 001 *Storz Couplings, Adaptors & Reducers*.

Where a tank is not located in a secure area, each valve must be padlocked in the closed position with the padlock keyed equivalent to the Lockwood 003 lock.

NOTE: *The use of traditional hydrant landing valves is permitted only where the valve jumper is held captive in the valve spindle. It has been found that with the traditional hydrant valve, the rubber washer vulcanises to the valve seat due to heat from direct sunlight, and the jumper remains securely in place when the valve spindle is raised because there is insufficient static pressure to lift the valve jumper.*

5.1.1 CFS Areas

Small bore: each tank, or a common tank manifold, must be fitted with a minimum of 2x 65mm nominal bore, rigid feed connections, each comprising a 65mm diameter, level-operated ball or butterfly valve, or a gate valve, each with a 65mm nominal bore Storz connection with a blank cap and captive chain.

Large bore: each tank, or a common tank manifold, must also be fitted with not less than one suction point comprising a 125mm Storz connection suitable for use by the CFS. The connection must include a 125mm – 100mm Storz adaptor, fitted with a 100mm cap and captive chain.

5.1.2 MFS Areas

Each tank, or a common tank manifold, must be fitted with one large bore suction point comprising a 150mm Storz connection, complete with a metal plug and captive chain.

150mm large bore connections are rated up to 60 L/s. Where the system flow is greater than this, additional connections will be required.

5.1.3 Dual Response (Mutual Aid) Areas

Each tank, or a common tank manifold, must be fitted with a minimum of 2x 65mm nominal bore, rigid feed connections, each comprising a 65mm diameter, level-operated ball or butterfly valve, or a gate valve, each with a 65mm nominal bore Storz connection with a blank cap and captive chain.

Each tank, or a common tank manifold, must be fitted with not less than one suction point comprising a 150mm Storz connection with a 150mm to 125mm Storz adaptor, and a 125mm to 100mm Storz adaptor, fitted with a 100mm blank cap and captive chain.

5.2 Suction Isolating Valve

Each large bore suction connection must be provided with a lever or gear operated, normally closed butterfly stop valve, of not less than 150mm nominal bore (see Figure 1 for more

BUILT ENVIRONMENT SECTION POLICY 14: ABOVE GROUND WATER STORAGE TANKS FOR FIRE FIGHTING PURPOSES

information). Where a tank is not located in a secure area, then each valve must be secured in the closed position by a padlock keyed equivalent to the Lockwood 003 lock.

5.3 General Pipe and Valve Requirements

All pipe and pipe fittings used in above ground fire hydrant and/or tank installations, including booster connections, must be in accordance with AS 2419.1. As per this Standard, plastic pipes and pipe fittings are not permitted to be used for any part of the systems that is above ground.

Valves suitable for use with water storage facilities as detailed in this document must:

- a) Be of **all-metal** construction in accordance with AS 2419.2 *Fire hydrant installations, Part 2: Fire hydrant valves*.
- b) Be capable of being locked in the open or closed position as appropriate.
- c) Be listed by the water supply authority and suitable for the working pressures experienced at the valve location.

Butterfly stop valves comprise two principal parts the valve body and the valve operator, and must incorporate the following:

- i) Employ an **all-metal** construction, low torque, gear-driven wheel or crank operator complete with a "Chisel" or equal type raised valve position indicator. This must indicate to a fire fighter by feel, through protective gloves, the position of the valve, and in normal circumstances will readily visually indicate the position of the valve butterfly when the valve actuator is viewed from above or to the side; or
- ii) Employ an **all-metal** construction lever operator with notch plate to permit partial opening of the valve. The position of the lever is to be parallel to the longitudinal axis of the pipe when the valve is open and must not interfere with the swing of any hose coupling keys used by fire fighters to attach hose to the outlet.

5.4 MFS Net Positive Suction Head Requirements

MFS pumps are designed to operate at their duty point (typically 1,000 GPM at 1,000 kPa) with a maximum Net Positive Suction Head (NPSH) of 3.0m (H₂O). All tank installation designs are considered to be high demand (tanks below ground or remote from the booster) should be reviewed to determine the actual NPSH required.

5.5 Quick Fill Facilities

Where reticulated mains supply is available automatic inflow and manual quick fill facilities are required to be provided in accordance with AS 2419.1. All tank infill facilities shall be located such that they are visible from the suction connection location(s).

Where automatic inflow facilities are provided, a manual by-pass quick fill facility should also be provided.

BUILT ENVIRONMENT SECTION POLICY 14: ABOVE GROUND WATER STORAGE TANKS FOR FIRE FIGHTING PURPOSES

The water supply to a site must be able to satisfy the flow requirements for all firefighting systems operating simultaneously for the required duration.

See Figure 2 for further information.

***NOTE:** Automatic infill is required where the effective storage capacity of the tank(s) has been reduced to allow for make-up supply in accordance with AS 2419.1.*

5.6 Vortex Inhibitor (Anti-Cavitation Plate)

Vortex inhibitors are required and shall be provided in accordance with AS 2419.1. Where the tank serves a combined hydrant and sprinkler system and a combined flow rate in excess of 40 L/s is required, the design of the vortex inhibitor shall be in accordance with AS 2118.1 suitable for the specified flow conditions.

5.7 Tank Contents Indicator

Each tank shall be fitted with a tank contents indicator in accordance with AS 2419.1. See Figure 3 for examples.

Tank contents indicators shall be visible from each tank suction outlet. Where a booster is provided that is located remote from the tanks (the tanks are not visible from that location) then remote tank level indication shall be provided within the booster cabinet.

5.8 Signage

Water storage tanks for firefighting shall have the following signs written in upper case lettering in a colour contrasting with that of its background. The following signs are required as a minimum:

- a) Where the tank storage forms part of a fire hydrant system in accordance with AS 2419.1 (i.e. is a fire hydrant tank), then the tank shall be identified with signage in accordance with AS 2419.1.
- b) Where the tank storage does not form part of a fire hydrant system in accordance with AS 2419.1 (i.e. is a standalone water storage tank), each tank shall be identified with the signage "WATER FOR FIRE FIGHTING" and the tank capacity written in 100 mm lettering on the side of each tank and repeated so that the sign is visible from all approaches to the tank. The sign shall be in fade-resistant lettering in a colour contrasting with that of the background.
- c) Each contents indicator shall be sign-written, as per AS 2419.1.
- d) Each quick fill valve shall be engraved or sign-written in a fade-resistant method in a colour contrasting with that of the background, in upper case lettering not less than 50mm in height as follows:

BUILT ENVIRONMENT SECTION POLICY 14: ABOVE GROUND WATER STORAGE TANKS FOR FIRE FIGHTING PURPOSES

- i) For automatic infill valves:
"AUTOMATIC TANK INFILL VALVE"
- ii) For manual quick fill valves:
"MANUAL TANK QUICK-FILL VALVE FOR FIRE FIGHTER USE"

6 TANK CAPACITIES

In accordance with AS 2419.1:

*"the minimum capacity of the source of water supply for fire hydrant installations shall be not less than that necessary to satisfy the minimum flow rates specified in Clause 2.3.1 or 3.3, as appropriate, for a duration of not less than **4 hours**."*

Further:

"Where the town main is capable of providing make-up supply to the on-site storage, the capacity of the on-site storage shall be such that a 4 h supply is available based on the difference in flow rates between the fire hydrant system required flow rate and the make-up flow rate."

Where the effective storage capacity of the tank is reduced in accordance with AS 2419.1 to incorporate an automatic inflow to supplement the supply from a reticulated town main, **no on-site storage tank shall have a useable capacity of less than 30 minutes supply at the required flow rate for the individual / combined systems**, as appropriate.

Further, where the effective storage capacity of the tank is reduced as per above **and the flow requirements of AS 2419.1 are for the operation of 1 hydrant valve only**, then no on-site storage tank shall have a useable capacity of less than 25,000L.

NOTE: See AS2419.1 for further details regarding on-site tank storage capacities.

Notwithstanding the above, Minister's Specification SA H3.2 *Concessions and specific requirements for farm buildings* may provide concessions in relation to the onsite tank storage capacities and make-up flows for firefighting water storage tanks for certain farm buildings. Farm buildings approved under Minister's Specification SA H3.2 must comply with the minimum firefighting water storage requirements of that document.

7 OVERFLOWS & MICROBIOLOGICAL AIR BREAKS

Overflow pipe sizes and air space between the ball valve and tank water level must be designed in accordance with AS/NZS 3500 and suitable for the ball valve size only. Quick fill pipes must be raised above the water level a minimum of 4 times the diameter of the pipe. The tank must be sufficiently robust and be complete with suitable relief openings in the tank lid to accommodate overflow should a manual quick fill valve be left on with the tank completely full of water. The water supply authority must be consulted to assess if any back flow prevention device is required for the ball valve, which could be submerged for a short period if a manual quick fill is allowed to overfill the tank. (See Figure 2 for further information).

BUILT ENVIRONMENT SECTION POLICY 14: ABOVE GROUND WATER STORAGE TANKS FOR FIRE FIGHTING PURPOSES

8 MULTIPLE TANKS

Where multiple tanks are required for the water supply, each tank must provide an independently valved water supply. Where only two tanks are provided, each valved connection must be not less than 150mm in diameter. Where 3 or more tanks are provided, each valved connection must be not less than 100mm in diameter. A common manifold interconnecting each valved tank must be of not less than 150mm nominal bore.

***NOTE:** A 150mm bore is required for a suction connection. Where two tanks are provided, when one is shut down the remaining tank must supply the total flow. For more than two tanks, a minimum of two supplies will be available, hence the permitted reduced tank connection size.*

9 EXAMPLES OF SYSTEM ARRANGEMENTS

Figure 4 shows a typical system arrangement where the performance of the street main does not meet the design requirements of AS 2419.1.

Figure 5 shows a tank system where pumps are provided to achieve the required performance specified in AS 2419.1. In this instance, a pump appliance is connected to the tank and can supplement the pumped supply.

Whilst a large incoming water supply is shown in this figure with provision for a fire appliance to draw water from a twin outlet feed hydrant, in some cases where only a small domestic water supply is available, the tank will be a stand alone facility with no large bore water supply. In such instances, a ball valve make up supply will be necessary having a performance sufficient to compensate for evaporative and routine hydrant flow test losses.

Figure 6 shows acceptable interconnections between fire storage tanks.

Figure 7 shows acceptable hardstand arrangements and dimensions for fire service pump appliances in relation to single/dual tank suction connection arrangements. Where more than two pump appliances are required, the hardstand area shall be increased as required.

BUILT ENVIRONMENT SECTION POLICY 14: ABOVE GROUND WATER STORAGE TANKS FOR FIRE FIGHTING PURPOSES

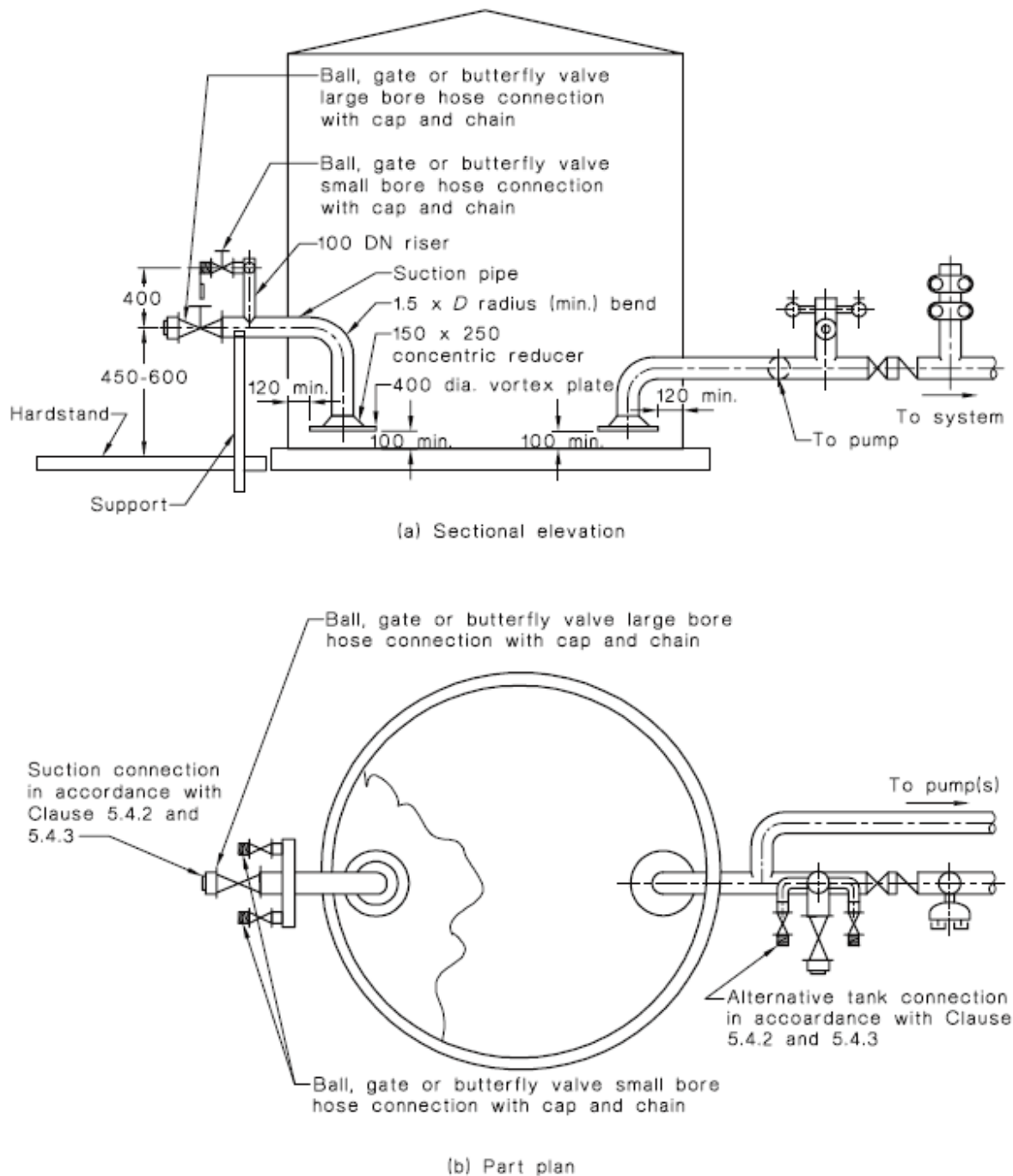

DIMENSIONS IN MILLIMETRES

Figure 1 - Typical arrangement of fire brigade connections to an above-ground external storage tank (shows vortex inhibitor suitable up to 40 L/s) (taken from AS 2419.1 Figure 5.4.2). Refer Section 5.1 for specific tank suction connection requirements.

BUILT ENVIRONMENT SECTION POLICY 14: ABOVE GROUND WATER STORAGE TANKS FOR FIRE FIGHTING PURPOSES

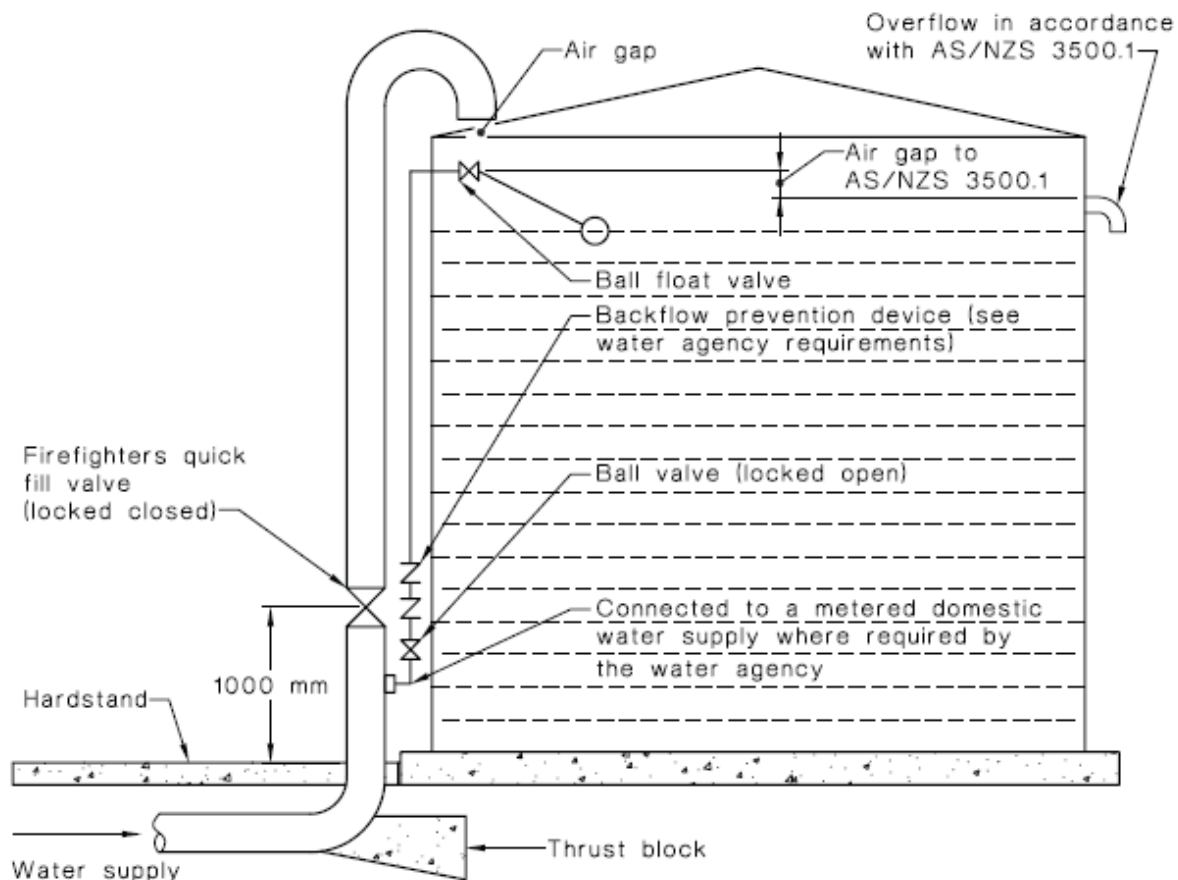

Figure 2 - Typical sectional elevation of an above-ground external storage tank showing fill and quick-fill arrangements (taken from AS 2419.1 Figure 5.2.3)

**BUILT ENVIRONMENT SECTION POLICY 14:
ABOVE GROUND WATER STORAGE TANKS FOR FIRE FIGHTING
PURPOSES**

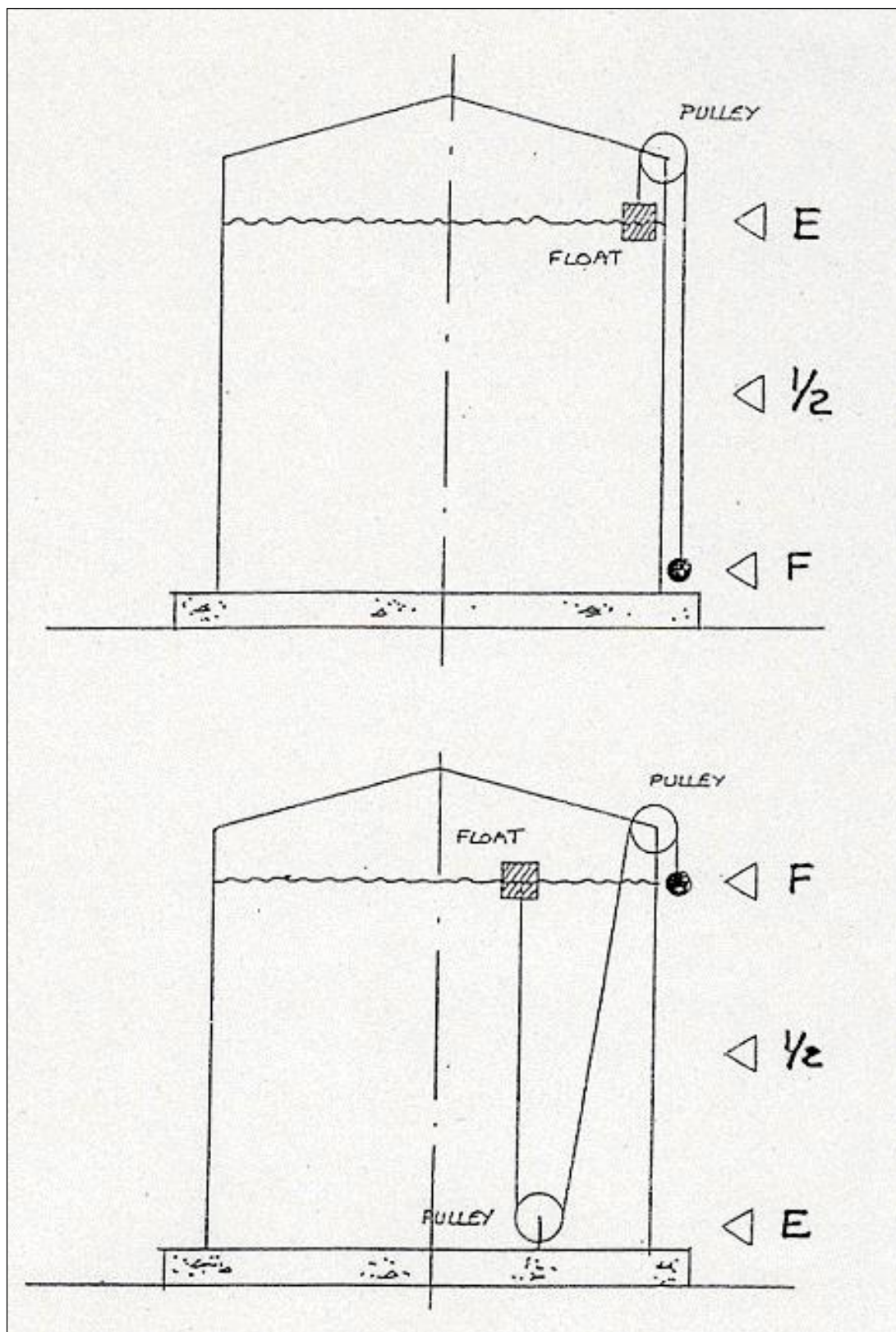

Figure 3 – Typical tank contents indicators.

**BUILT ENVIRONMENT SECTION POLICY 14:
ABOVE GROUND WATER STORAGE TANKS FOR FIRE FIGHTING
PURPOSES**

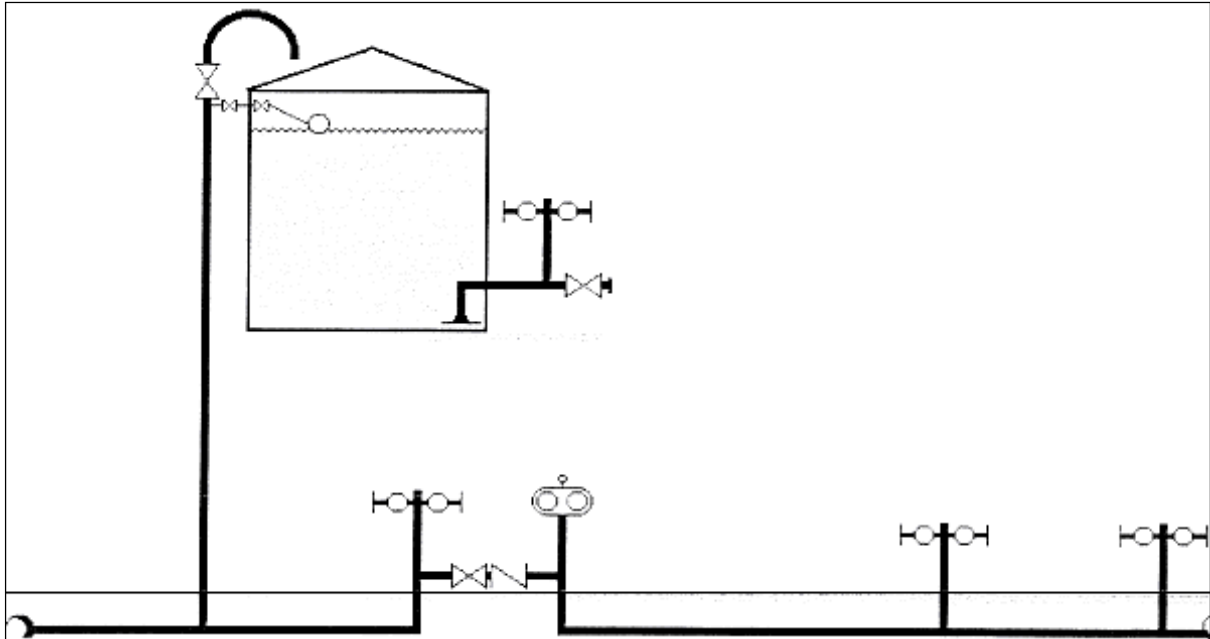

Figure 4 - Water supply when the flow rate is below that required.

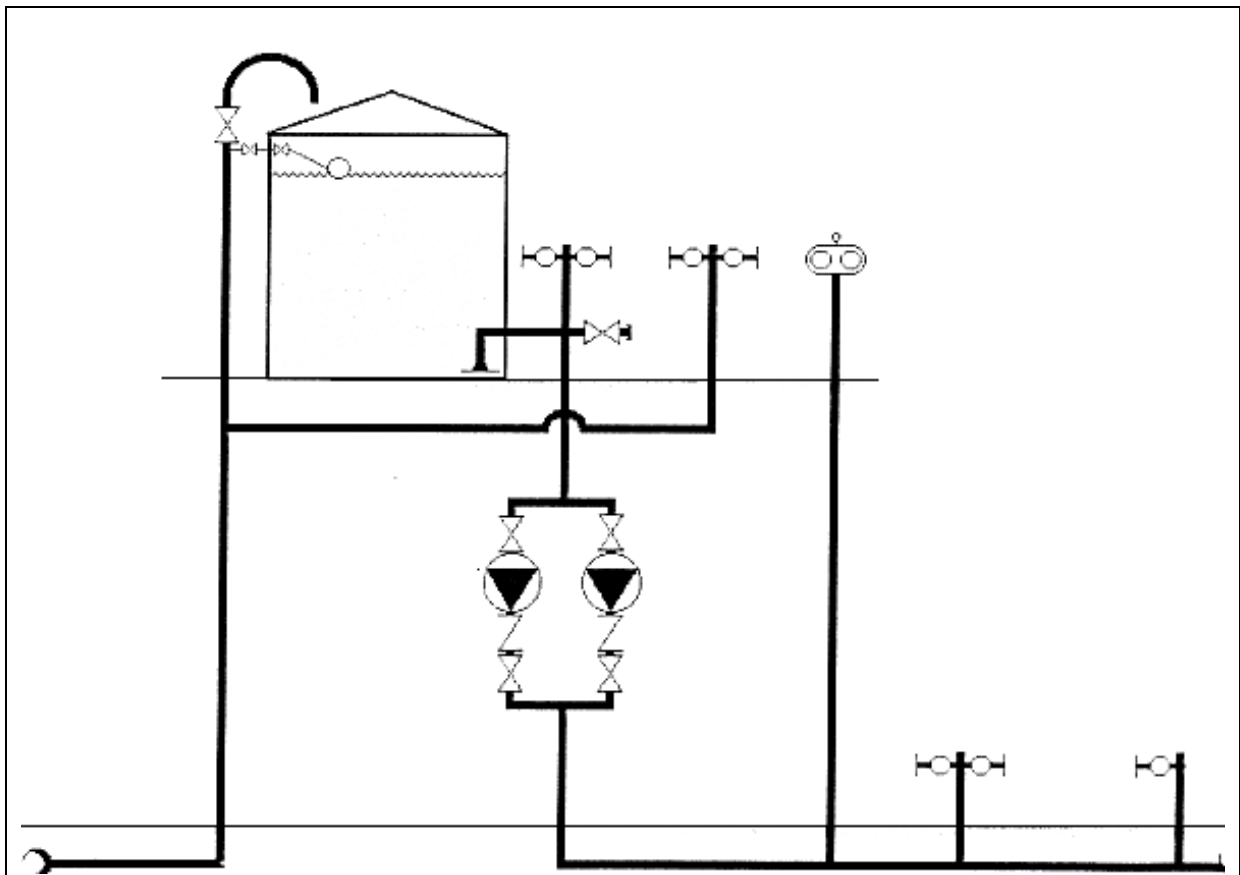

Figure 5 - Pumped system water supply when the flow rate is below that required.

**BUILT ENVIRONMENT SECTION POLICY 14:
ABOVE GROUND WATER STORAGE TANKS FOR FIRE FIGHTING
PURPOSES**

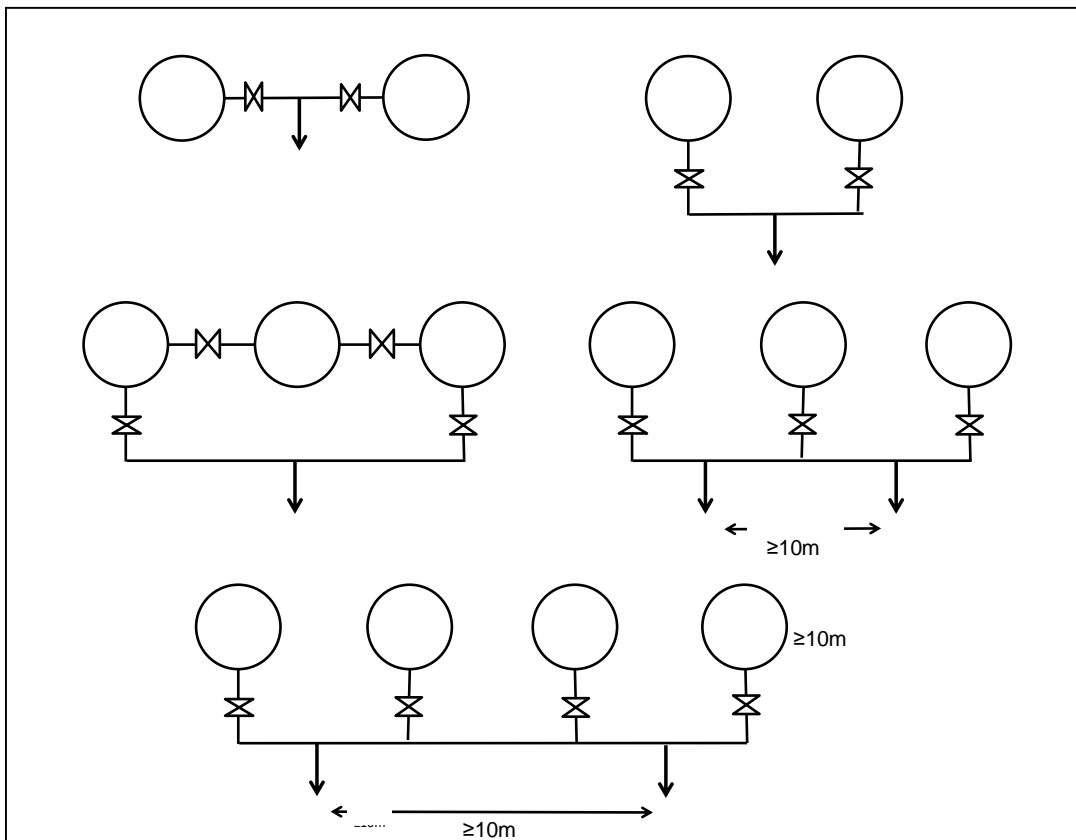

Figure 6 - Acceptable tank connection arrangements for multiple storage tanks.

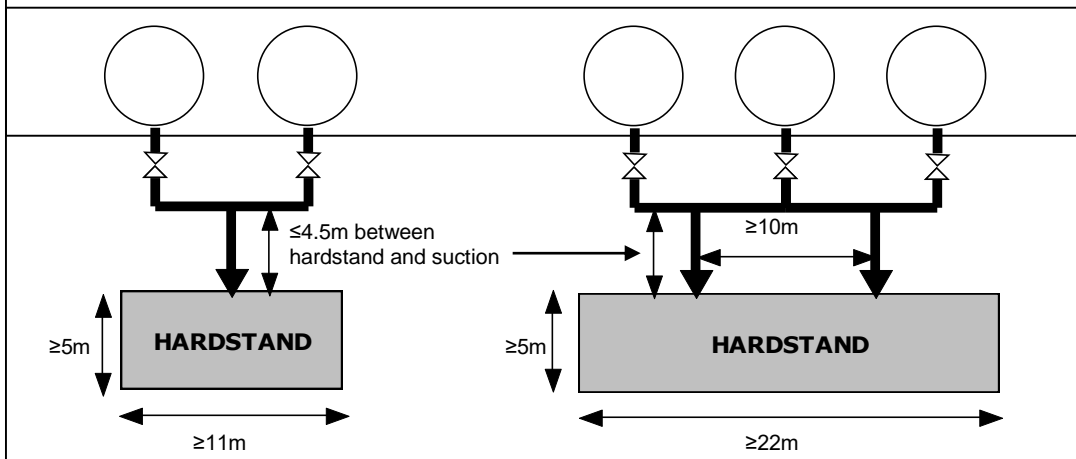

Figure 7 - Acceptable hardstand arrangements for fire service pump appliances.